



AMCOT COOLING TOWER CORPORATION

***OPERATING INSTRUCTIONS
AND SERVICE MANUAL***

FOR MODEL ST 3~1500

***AMCOT COOLING TOWERS
1-800-444-8693***

INTRODUCTION

Adequate knowledge about cooling tower maintenance and operation will allow you to perform inspections and service your own tower to ensure that performance and structural integrity do not decline over the life of your cooling tower. This knowledge will allow you to operate your cooling tower safely and with optimum performance. The following steps are intended to provide you incite and allow you to prevent or foresee problems that may occur as a result of normal operation. PLEASE READ THROUGH THIS MANUAL COMPLETELY BEFORE RUNNING YOUR COOLING TOWER. Any questions, comments or suggestions should be expressed to the Amcot Cooling Tower Corporation.

1. Tower Construction

1.1 Type

The Amcot ST-model is an induced draft counter flow design with a propeller type fan blade mounted on the top of the cooling tower. The bottle shaped tower provides lower pressure loss that enables Amcot to generate high CFM levels with smaller sized fan motors.

1.2 Casing

The Fiberglass Reinforced Polyester (FRP) is composed of fiberglass mats laminated from unsaturated polyester resin. The high structural strength of the material protects the unit against impact and cracking. Gel coat is applied for UV protection and to provide a glossy finish.

1.3 Water Basin

Also made of F.R.P. materials, the bowl shaped basin with a cylindrical suction sump (ST-200~1500) keeps cavitation of the pump to a minimum. A drain connection is provided for removal of solids that could prevent scaling. The drain is also used for draining the tower during non-operating seasons. An overflow connection is provided to prevent spill out or flooding of the surrounding area in an event that malfunction occurs. The automatic float valve, Los Angeles mechanical certified, helps maintain water levels during operation.

1.4 Tower Support Framework

A) ST-3~175

The F.R.P. base legs are incorporated with the water basin in a single unit to withstand high wind load conditions and minimize vibration.

B) ST-200~1500

Provided with hot dipped galvanized steel or stainless steel leg supports.

1.5 Motor Support Frame

Made of hot dipped galvanized steel or stainless steel depending on options you have chosen.

1.6 Air Inlet Louver

The PVC plastic mesh is fitted on the air inlet to prevent foreign materials from falling into the basin and blocking your outlet pipe connections.

1.7 Filling

Made of rigid polyvinyl chloride sheets which is embossed and corrugated into a honeycomb configuration that provides maximum air-to-water contact for higher levels of heat exchange.

1.8 Water Distribution

A set of sprinkler arms and a sprinkler head mounted onto the stand pipe of the cooling tower allows even distribution of water over the fill material. The sprinkler head rotates by use of circulating water pressure. Numerous holes located on the sprinkler pipes provide the even distribution. Adjusting the angle can regulate the speed of these sprinkler heads. When the distribution holes are facing straight downwards, the sprinkler pipes will not rotate due simply to the fact that no force is being used to push the sprinkler system around. As you increase the angle of the sprinkler pipes, rotation will be generated. Excessive rotation will lower cooling efficiency and increase drift loss. Please see Revolution Speed of Sprinkler Head chart.

- A) **ST-3~60** (refer to figure 1) constructed of nylon material, the sprinkler pipes connect to sprinkler head by way of a threaded connection and a lock nut.
- B) **ST-70~1500** (refer to figure 2) constructed of Aluminum Alloy and is fitted with sealed bearings to provide smooth rotation. Sprinkler pipes are locked in place by way of setscrews.

1.9 Fan Blade

Fan Blades are propeller design providing quiet operation and maximum airflow-to-Horsepower ratios. It is important to check that fan blade is corrected properly. This can be identified by arrow markings on the fan blade. These marking should be seen when looking down into the tower from where fan motor and fan guard are located.

- A) **ST-3~30** – Constructed out of reinforced plastic material. Fan Blades are coupled to hub by screws and bonding material to prevent malfunction. Pitch angles are preset for maximum airflow.
- B) **ST-40~50** – Constructed out of aluminum alloy blades and a nylon hub. The blades are attached in the same fashion and pitch is not adjustable.
- C) **ST-60~1500** – Constructed of aluminum alloy, these blades are locked in place using U-bolts. Fan pitch is factory set, but can be adjusted to minimize drift loss. (NOTE: Pitch angles can cause higher or lower amperage draw on fan motor. Please use caution when adjusting and be sure to verify that amperage is still within 5~10% of indicated amperage rating on motor nameplate.

2.0 PREPARATIONS FOR STARTING

2.1 Cleaning of Basin

Open the drain at the bottom of the water basin and wash dust and debris with use of water and a brush.

2.2 Cleaning system

Fill basin with water until float valve shuts off. Check sprinkler pipes and sprinkler head to ensure smooth rotation. Turn circulating pump on and allow water to circulate for 5~10 minutes. This will remove any debris from the cooling tower or system and clean equipment pipes. Drain tower water and be sure to remove excess debris from basin once more. Check sprinkler head revolution chart to verify that your distribution system is falling within recommended parameters. Adjust if needed.

2.3 Checking

Check to be sure that sprinkler pipes are secured to sprinkler head. Check V-belts (if applicable) to make sure they are tight. Check fan motor electrical connections to prevent bad wiring, which could result in motor burn out. Turn fan to make sure it revolves and that the shaft is not frozen. If it is, CALL AMCOT IMMEDIATELY. Be sure that fan blade tips are not touching casing panels. Turn fan motor on briefly to verify that air is blowing upwards and that there is not excessive vibration. Make sure that the nuts and bolts are fastened tightly.

3.0 **STARTING**

3.1 **Pump Driving**

When you are ready to startup your cooling tower, be sure that there is adequate water within the basin. If water level is not high enough when you begin the pump air can be pulled into the pump causing cavitation. If this occurs shut down the pump and allow water to recede into the basin. Fill with additional water and restart. When you begin, open flow control valves and turn on pump. As water circulates, use the valve to adjust flow rate as specified on the nameplate. Be sure to recheck the sprinkler pipes once you have the corrected flow rate measuring on the valve. Sprinkler pipes may need to be adjusted slightly to guarantee proper cooling performance. Use the chart below to define what the revolution speed should be.

SPRINKLER HEAD RECOMMENDED RPMs								
ST-Model Number	3	5~30	40~60	80~250	300~350	400~700	800~1000	1250~1500
RPM	12~17	7~10	5~8	5~7	3.5~5	2.5~4	2~3	1.5~2.5

3.2 **Fan Driving**

If you have not done so, please check your electrical wiring and be sure that the motor is wired as shown in the wiring diagram section. If you have any questions, contact Amcot. If wiring is correct, turn on fan motor. Once the motor reaches full speed, it is recommended that you measure phase voltages and phase currents to see that the motor is running as specified on the motor nameplate.

4.0 **Cautions During Operation**

4.1 **Performance**

Since the volume of circulating water will affect the cooling tower performance, be sure to maintain the designed water flow rate at all times. It is important that you take steps towards preventing algae and scale build up. With proper water treatment, you can minimize these items and increase the life of your cooling tower and equipment. It is best to contact the contractor or distributor in your local area to see whom they recommend.

4.2 **Water Level**

Air can be pulled into the pipes causing cavitation if the water level becomes too low. Be sure that the float valve has been adjusted appropriately to maintain a steady water level.

4.3 **Functioning**

Pay close attention to vibration, noises, water temperatures, and voltages. These events can be a warning that something is not right and that you may need to replace an item soon. Excessive vibration is caused by the fan motor being unbalanced and is often a result of scale or algae build up. Water temperatures can indicate that fill material is blocked, water distribution pipes are blocked, or pump is malfunctioning. Voltage currents can indicate problems with the fan motor or reducer.

5.0 Maintenance and Control

5.1 Sprinkler Pipes

The pipes must be free of any blockage. If there is buildup within the pipe system, performance will decrease and this is signified by an increase in cold water temperature. Take the following steps to prevent buildup:

- A) Loosen set screw or lock nut on sprinkler pipe. Remove the pipe from the tower and clean out.
- B) Using a screwdriver, use the end and insert into pipe holes to breakup any blockage that has sealed these holes off.
- C) Insert sprinkler pipe back onto sprinkler head, adjust angle and tighten.

5.2 Sprinkler Head

Sprinkler head will fail to rotate smoothly and efficiently if scale buildup becomes too great. If this occurs, take the following measures:

A) ST-3~60 (Figure 1)

- a. Remove set screw cap on top of sprinkler head.
- b. Loosen nut and washer, then remove sprinkler head.
- c. Clean sprinkler head with fresh water and a brush. Check parts to see if they are worn or bad.
- d. If everything appears to be ok, reinstall sprinkler head. If problem persists it may be necessary to replace with a new head.

B) ST-70~1500 (figure 2)

- a. Remove the cap and take circlip off.
- b. Pull the rotary part (head) off of the fixed part (body).
- c. Clean in same manner as above and reinstall.
- d. It may be necessary to replace bearings or entire sprinkler head depending on extent of damages.

Sprinkler Head Reference Numbers										
ST Model Number	3~10	15~20	25~40	50~60	70~100	125~175	200~250	300~400	500~700	800~1500
LSH Model Number	-040-	-050-	-065-	-080-	-100-	-125-	-150-	-200-	250-	-300-

Item Number	Sprinkler Head Bearings					
	LSH-100	Lsh-125	LSH-150	LSH-200	LSH-250	LSH-300
Bearing A	6301Z	6302Z	6302Z	6303Z	6304Z	6305Z
Bearing B	6302Z	6303Z	6303Z	6304z	6305Z	6306Z

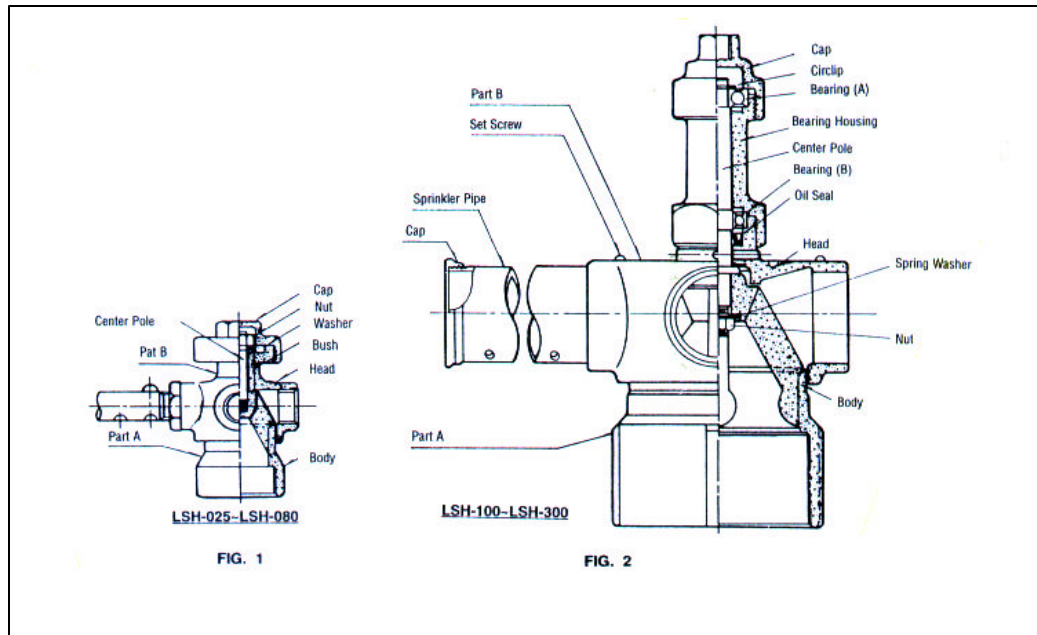

5.3 Casing

Gel coating is applied at factory before shipping. This coat will lose its glossy finish and eventually begin to deteriorate. Wash down the outside of the cooling tower with fresh soapy water and a sponge. This will help to keep the gel coat from flaking or cracking and the tower will retain its appearance. Overtime nothing can prevent the tower from losing its glossy finish.

5.4 Water Basin

As dust and debris is found everywhere, it is impossible to prevent all dusts and dirt from entering the system. It is vital to generate a bleed depending on concentration of solids. This will help maintain water basin integrity and prevent deterioration. Basin is designed to withstand water but, solids at high levels can cause some moderate damage in which patching may be required.

5.5 Filling

No special care is needed if the control of water quality is well-managed then fill can be left untouched for years. With bad water treatment or bad water quality, fill can have buildup and this will lower efficiency. Using a high velocity spray nozzle and spraying down into the fill can often solve blockage. If blockage is severe enough, fill replacement may be necessary.

5.6 Fan

Check fan blades carefully to ensure that no cracks or buildup occurs. Buildup can cause fan to fall out of balance and therefore excessive vibration will occur. Cracks can lead to fan blades breaking and causing severe internal damage

Fan Blade Reference Numbers											
ST-Model Number	3~8	10~15	20~30	40~50	60~80	100~125	150~200	225~350	400~500	600~700	800~1500
LSF Model Number	-050	-070-	-080-	-100-	-120-	-150-	-180-	-240-	-300-	-340-	-360-

5.7 Fan Motor

Amcot Fan Motors are UL recognized and of TEFC construction. Standard Fan Motors are single speed single phase and three phase, depending on size of tower. Two speed motors are available through our U.S. Motor Manufacturer. Teco Electric, Tatung motor Company and Lung Tung Industries manufacture our standard motors. All of these motors have a service factor of 1.15, insulation class E, and have various electrical approvals (UL, CSA, ETL, etc..) along with ISO awards. These motors are built for harsh environments and can withstand above average weather conditions and events.

- A) ST-Models 3~20 – Single Phase 110/220v
- B) ST-20 – Single / Three Phase 110/220v or 208/230/460v
- C) ST-30~1500 – Three phase 208/230/460v or 220/440v (check nameplate for verification)

Below are wiring Diagrams. Find the desired voltage and wire accordingly. If you have any questions, please contact Amcot. If wired incorrectly, motor will burn out, please recheck before starting.

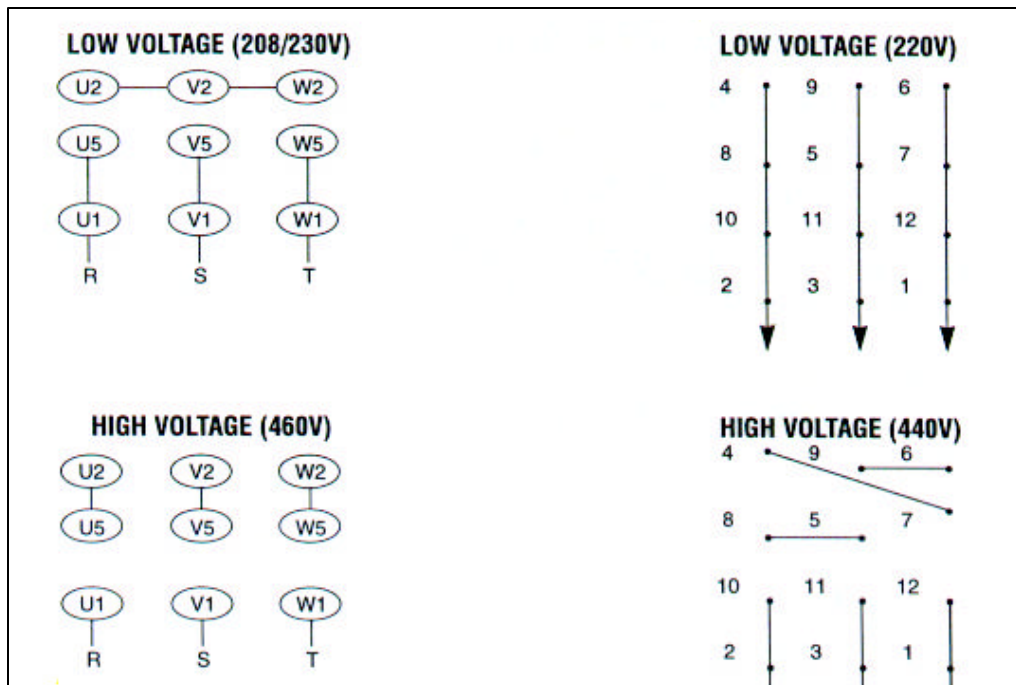

6.0 **V-Belt Speed Reducer**

With more attention being directed to noise, Amcot has designed a V-belt drive design to reduce the noise levels emitted by the cooling tower.

This new drive produces lower dB levels, is compact and lighter in weight than the conventional gear driven reducers. With the special V-belts, you are able to generate identical performance and gain these additional advantages. The belts are made from polyurethane, which uses polyester tension cords as the tensile member. It is important to remember that proper maintenance is required or the belts' life expectancy can be severely decreased. Follow the steps below and you belts can last for as long as 10,000 operating hours.

6.1 **Belt Adjustment**

Before operation, open the adjustment access cover and check to make sure that the washer on the adjusting bolt is aligned with the adjusting gauge (Ref. Fig.A.).

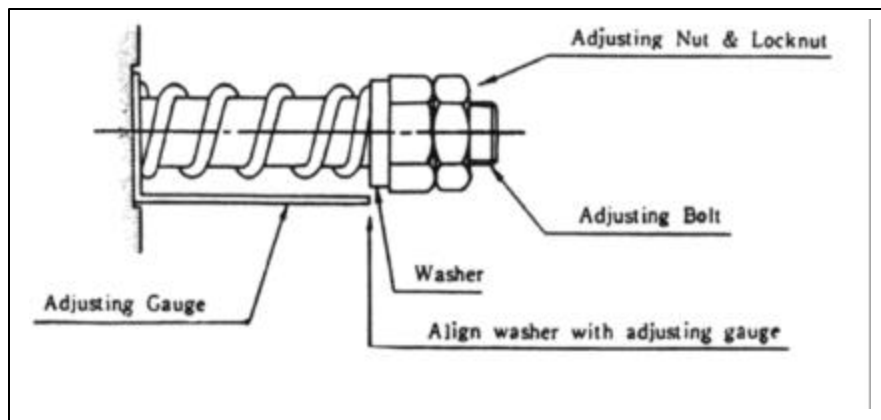

During Operation the belt may stretch causing them to slip. This will cause abrasions or cuts that can cause belts to break. Belt tension is important to ensure proper cooling tower performance and to maintain the life of the belts.

- (A) 50 hours after initial startup.
- (B) Three sequential checks at 100-hour intervals.
- (C) After this fourth check at 350 hours, check the belts on a monthly basis.

Off-Season Shutdown – When long periods of shutdown are used, slacken the adjusting nut by $\frac{1}{4}$ of an inch to prevent belts from stretching. Readjust the belts prior to putting the cooling tower back into operation.

Adjustment Precaution- If a gap exists between the adjusting gauge and the washer, the belts have too much slack. If the washer and the adjusting nut overlap the adjusting gauge then the belts are too tight.

Proper tension on the belts will allow the belts to operate accordingly. The adjusting gauge is set by the factory and should not be altered.

6.2 **Testing of Drive Operation**

After checking the tension of the V-Belts and once this is established to be correct close the access door. Spin the fan blade to make sure that the unit is rotating smoothly. Begin the fan motor for two hours checking amperage and voltage to make sure that they comply with the fan motor nameplate. If the readings do not match the nameplate, consult Amcot for advice.

6.3 **Maintenance**

The following work should be performed when performing maintenance.

(A) Drive Section

Clean out the inside of the driving section annually.

(B) Motor Insulation

Before the cooling season each year, check the insulation of the motor. This can be done with a 500-volt meager. A resistance greater the $1M\Omega$ is acceptable.

(C) Bearings

Although it is not necessary to lubricate the sealed bearings, an annual change of grease will extend their life. To repack the bearings, remove the seal plates with a sharp tool inserted as indicated in figure B. Replace the seal plates after repackaging the bearings.

(D) V-Belts

Maintain tension levels as indicated before to maximize the life of the V-Belts. Average life of these belts when maintained appropriately will be between 5,000 and 10,000 operating hours. If belts begin to slip or have visual abrasions after 5,000 hours then these belts are showing sign of wear and should be replaced to prevent a sudden shutdown. Another sign that the belts require replacing is if after 5,000 hours continual adjustment that is required to maintain tension. This means that the belts have lost their tautness and should be replaced.

Belts are supplied in matched sets and must be sold in this fashion or else one belt may be tight while the other is loose.

To Replace belts, remove the belt cover from the reducer. Loosen the adjusting nut and slide the intermediate pulley assembly towards the motor as in Figure C. Remove old belts; insert new set and replace.

MOTOR and V-BELT SPEED REDUCER

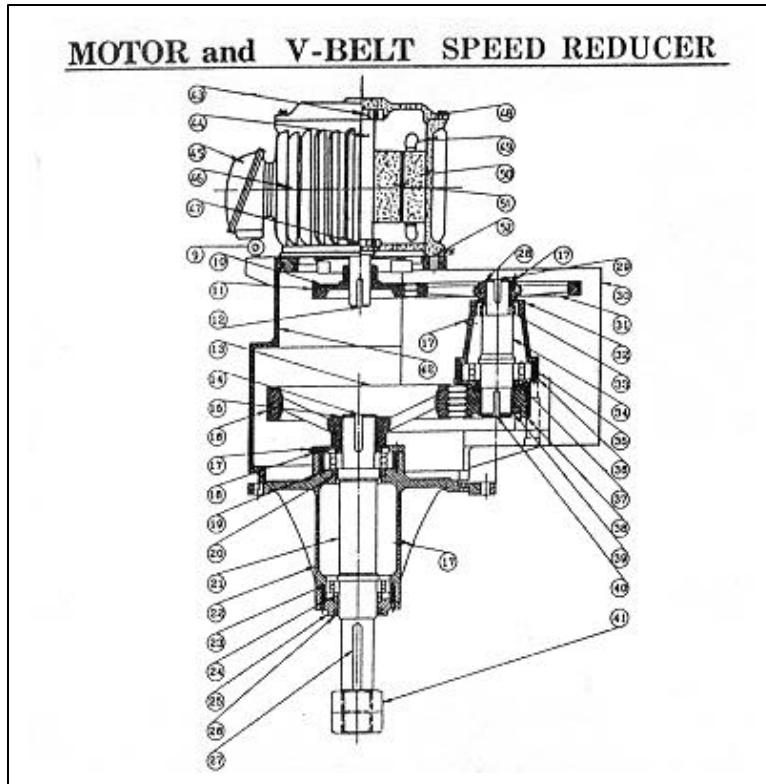

Item No.	Description
1.	Support Pin
2.	Adjusting Lever
3.	adjusting Gauge
4.	Adjusting Spring
5.	Washer
6.	Adjusting Bolt
7.	Sight Glass
8.	Cooling Fan
9.	Lifting Ring
10.	Pulley No.1
11.	V-Belts (Upper)
12.	Key A
13.	Pulley No.4
14.	Key D
15.	Circlip D
16.	V-Belt (Lower)
17.	Grease Nipple
18.	Housing Cover No.1
19.	Bearing D.
20.	Oil Seal D
21.	Fan Shaft
22.	Housing (Fan Shaft)
23.	Bearing E
24.	Bearing G
25.	Housing Cover No.2
26.	Oil Seal E
27.	Key E
28.	Circlip B
29.	Key B
30.	Belt Cover
31.	Pulley No.2
32.	Interm. Shaft Housing
33.	Bearing B
34.	Intermediate Shaft
35.	Bearing C
36.	(Interm. S.) Housing Cover
37.	Oil Seal C
38.	Pulley No.3
39.	Circlip C
40.	Key C
41.	Fan Shaft Nut
42.	Belt Case
43.	Bearing F
44.	Motor shaft
45.	Terminal box
46.	Stator frame
47.	Bearing A
48.	Set screw 1
49.	Stator coil
50.	Stator core
51.	Rotor core
52.	Set screw 2

V-BELT SPEED REDUCER SECTION

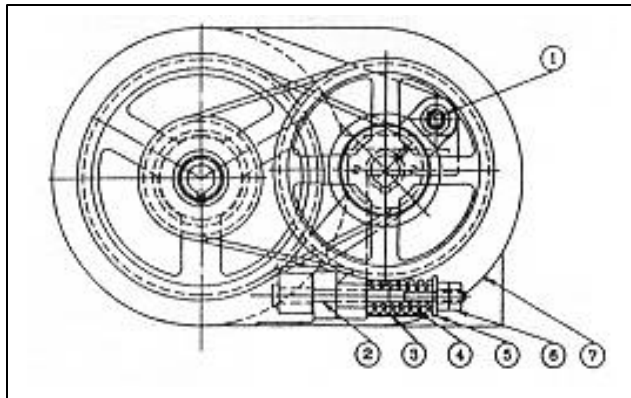

V-Belt Speed Reducer Bearing Table

V-belt Speed Reducer Model #	ST Model	Bearings						
		F	A	B	C	D	E	G
LBM-055C	225 & 250	6306zz	6308zz	6207z	6309z	6211z	6012z	51112
LBM-075	300 & 350	6306zz	6308zz	6208z	6310z	6211z	6012z	51112
LBM-110	400 & 500	6308zz	6309zz	6208z	6310z	6213z	6213z	51113
LBM-150	600 & 700	6308zz	6309zz	6209z	6313z	NJ313	NJ215	51115
LBM-220	800 & 1000	6309zz	6311zz	6213z	6317z	NJ317	NJ217	51117
LBM-300	1250 & 1500	6312zz	6312zz	6213z	6317z	NJ317	NJ217	51117

V-BELT TABLE 1

V-Belt Speed Reducer Model #	ST MODEL	FAN SPEED (R.P.M.)	V-BELT MODEL #	NUMBER OF BELTS UPPER	NUMBER OF BELTS LOWER	TOTAL BELTS PER SET
LBM-055C	225 & 250	398	2-11Ms-800	1	-	2
			3-11Ms-800	-	1	
LBM-075	300 & 350	398	2-11Ms-800	-	2	3
			3-11Ms-800	1	-	
LBM-110	400 & 500	342	2-11Ms-1400	1	-	2
			3-11Ms-1400	-	1	
LBM-150	600 & 700	282	2-11Ms-1400	1	1	3
			3-11Ms-1400	-	1	
LBM-220	800 & 1000	265	2-11Ms-1550	-	2	4
			3-11Ms-1550	1	1	
LBM-300	1250 & 1500	260	2-11Ms-1550	2	2	7
			3-11Ms-1550	1	2	

7.0 PRECAUTIONS IN PROLONGED IDLENESS

To prevent your pipe system from cracking during non-operational seasons, all water should be drained from the system. If you wish to save this circulating water, you can invest in low cost holding tanks that can be stored indoors. Be sure to follow the steps outlined within this manual to prevent damage to your sprinkler heads, sprinkler pipes, fan motor, and V-Belts. One last measure which you should partake in is to cover the upper section (where fan motor is located) with a tarp. This will prevent debris from falling through the fan guard and blocking the system once it is operational.

8.0 WATER TREATMENT

A. **Bacterial Contamination**

Bacterial Contamination within the circulating water is possible. It is crucial to both your surrounding environment and to your cooling tower, that a Water treatment program is planned and put into effect immediately. This water treatment should include bleeding of solids and a steady level of chemicals that should be monitored and maintained all the time.

Amcot is not an expert when it comes to water treatment. In fact there are hundreds of companies nationwide and internationally who offer these services. You would be safe to contact a local water treatment company who has experience in treating cooling towers and is open and willing to answer all your questions. There are good companies out there. If you find yourself stuck, contact Amcot and we will try to find someone for you.

B. **Water Quality Control**

Poor quality of water due to air pollution, corrosion, scale, and algae growth will impede the performance of all water-cooled equipment. We recommend a periodical water analysis and blow-down are initiated to maintain the water quality within the cooling system. Permissible water quality levels are as follows. If additional information on chemical allowance is needed, contact Amcot directly with those requests.

PERMISSIBLE VALUE OF WATER ANALYSIS

PARAMETER	MAKE-UP WATER	CIRCULATING WATER
pH LEVEL	6-8	6-8
ELECTRIC CONDUCTIVITY (mv/cm)	200 OR BELOW	500 OR BELOW
TOTAL HARDNESS (CaCO ₃) PPM	50 OR BELOW	200 OR BELOW
M ALKALINITY (CaCO ₃) PPM	50 OR BELOW	100 OR BELOW
Chlorine ion (CL ⁻) PPM	50 OR BELOW	200 OR BELOW
SULPHURIC ACID ION (SO ₄ ⁻) PPM	50 OR BELOW	200 OR BELOW
SILICIC ACID (SiO ₂) PPM	30 OR BELOW	50 OR BELOW
FERRIC (Fe) PPM	0.3 OR BELOW	1.0 OR BELOW

TROUBLE ANALYSIS TABLE

TROUBLE	CAUSES	COUNTER-MEASURES
RISE IN COOLING WATER TEMPERATURE	<ol style="list-style-type: none"> 1. Excess or inadequate cooling water flow 2. Irregular flow of air. 3. Recirculation of air exhausted from tower. 4. Irregular operation of sprinkler pipes. 5. Improper flow of air. 6. Blocking of the filling 	<ol style="list-style-type: none"> 1. Adjust to specified flow. 2. Improve ventilation 3. Same as above or install baffles. 4. Remove dust, debris and scale 5. Adjust angle of fan blade pitch. 6. Clean blocked areas.
DROP IN THE VOLUME OF COOLING WATER	<ol style="list-style-type: none"> 1. Blocking of the sprinkler pipe holes 2. Blocking of strainer mesh. 3. Drop in the water level of water basin. 4. Improper selection of circulating pumps. 	<ol style="list-style-type: none"> 1. See section for maintaining and adjusting 2. Remove strainer and clean. 3. Adjust Float Valve 4. Replace the pump with one matching the specifications.
NOISE AND/OR VIBRATION	<ol style="list-style-type: none"> 1. Fan blade tips touching fan stack. 2. Improper mounting of fan blades. 3. Loose bolts. 4. Shortage of speed reducer oil. 	<ol style="list-style-type: none"> 1. Adjust the fan mounting. 2. Correct the blade angle settings. 3. Tighten loose bolts. 4. Supply oil up to the level specified.
EXCESSIVE CURRENT DRAW	<ol style="list-style-type: none"> 1. Drop in voltage. 2. Irregularities in the angles of the fan blades 3. Overload through excess airflow. 	<ol style="list-style-type: none"> 1. Check supply voltage. Notify power company if necessary. 2. Adjust fan blade angels. 3. Adjust fan blade angels.
WATER CARRY-OVER	<ol style="list-style-type: none"> 1. Irregular operation of sprinkler pipes. 2. Blocking of the Fill. 3. Defective eliminators. 4. Too much circulating water. 	<ol style="list-style-type: none"> 1. Adjust the angle of the sprinkler pipes in the sprinkler head. 2. Eliminate blockage at the upper edge of the filling. 3. Renew the eliminator. 4. Adjust the water flow by means of the valve.